

Preparation unit——GA Series

GAR100 Series Regulator



Symbol

Reflux valve option is not available



Specification

Model	GAR100M5	GAR10006
Fluid	Air	
Port size [Note1]	M5	1/8"
Pressure range	0.05~0.9MPa(7~130psi)	
Max. pressure	1.0MPa(145psi)	
Proof pressure	1.5MPa(215psi)	
Temperature range	-5~70°C(Unfreeze)	
Weight	59g	

[Note1] PT thread, G thread and NPT thread are available.

Ordering code

GAR100 06 S **G**

① ② ③ ④ ⑤ ⑥ ⑦

① Model	② Port size	③ Type code	④ Accessories	⑤ Pressure gauge	⑥ Thread type[Note2]	⑦ Code of reflux valve
GAR100:GA100 Series regulator	M5: M5 06: 1/8	S: Standard L: Lower pressure [Note1]	Blank: Bracket J: No bracket	Blank: Circular N: No gauge	Blank: PT (MPa/psi) G: G (bar/MPa) T: NPT (psi/bar)	Blank: Reflux valve is not available

[Note1] The working pressure range of lower pressure type is 0.15~0.4MPa(20~58psi) ;

[Note 2] Thread type means connecting thread and scales of pressure gauge while port size is M5.

Pressure and Flow chart

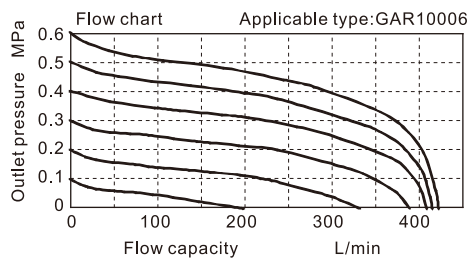
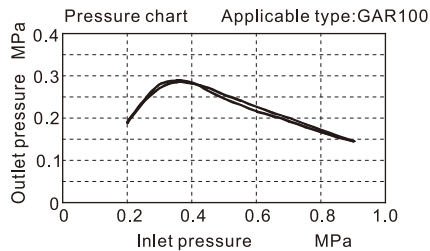

Dimensions

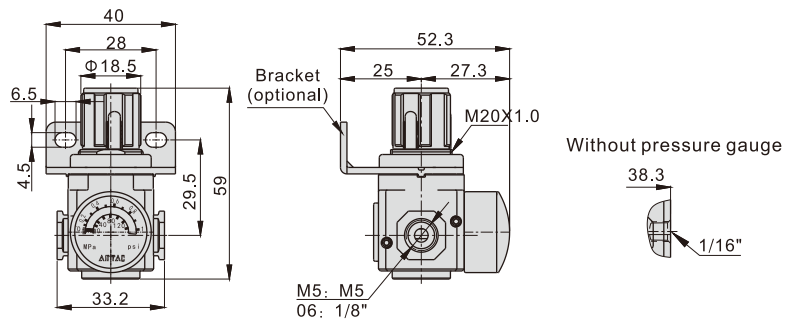

Inner structure

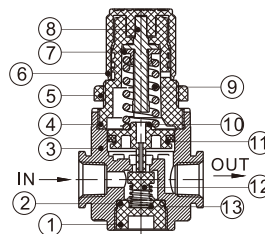

No.	Item	Material
1	Valve cap	POM
2	O-ring	NBR
3	Body	Aluminum alloy
4	Adjusting seat	POM
5	Fixed ring	POM
6	Pressure knob	POM
7	Spindle nut	Steel
8	Adjusting spindle	Steel
9	Spring	Spring Steel
10	Piston	POM
11	Piston O-ring	NBR
12	Pressure plug	NBR
13	Spring	Stainless steel