

Fluid control valve(2/2 way)

2KSA Series (Direct-acting and normally opened)



Symbol



Product feature

1. Direct acting and normally opened type 2/2 way fluid valve. Its high sensibility allows it to change direction quickly;
2. It has wide pressure range, including extra high pressure (X), high pressure (H), standard and large volume(L);
3. It is compact, small size and light weight. Easy to install and dismantle.
4. The valve body is made of SUS304. Its coil has a Heat resistance classification of Class F. The standard seal material is FPM-F. Please contact us if other seal material are required.
5. The protection class of the coil is IP65 and there is a choice for grommet or terminal electrical entry.

Specification

Model\Item	Port size [Note1]	Orifice size (Φmm)	Cv	Valid area or section(mm ²)	Weight [Note2](g)	Max.operating pressure differential		Proof pressure	
						MPa	psi	MPa	psi
2KSAX030	-06 1/8"	1.5	0.10	1.8	245	2.0	300	3.0	450
	-08 1/4"				235				
2KSAH030	-06 1/8"	2.0	0.18	3.0	245	1.5	220	3.0	450
	-08 1/4"				235				
2KSA030	-06 1/8"	3.0	0.33	6.0	245	0.7	100	3.0	450
	-08 1/4"				235				
2KSAL030	-06 1/8"	4.0	0.55	10.0	245	0.4	60	3.0	450
	-08 1/4"				235				
2KSAX050	-10 3/8"	3.0	0.34	6.1	530	2.0	300	3.0	450
	-15 1/2"				510				
2KSAH050	-10 3/8"	4.0	0.55	10.0	530	1.5	220	3.0	450
	-15 1/2"				510				
2KSA050	-10 3/8"	5.0	0.83	15.0	530	0.7	100	3.0	450
	-15 1/2"				510				
2KSAL050	-10 3/8"	7.0	1.40	25.0	530	0.4	60	3.0	450
	-15 1/2"				510				

[Note1] PT thread, G thread and NPT thread are available.

[Note2] The weight in the table is the terminal valve's weight, 2KSA030 series grommet valve's weight is 10g less than terminal's. 2KSA050 series grommet valve's weight is 20g less than terminal's.

Inner structure

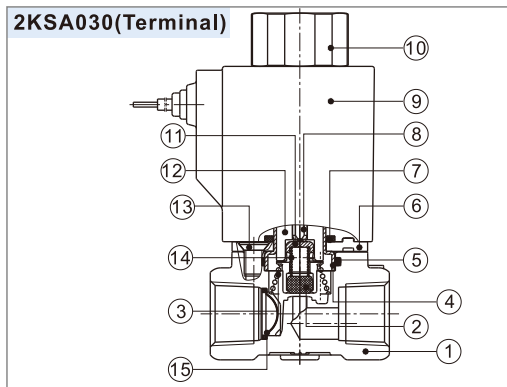

No.	Item	No.	Item	No.	Item
1	Body	6	Fixed plate	11	Airtight bush
2	Airtight ring	7	O-ring	12	Electromagnet
3	Spring	8	Mandril	13	Screw
4	Coil axis	9	Coil assembly	14	Spring
5	O-ring	10	Coil nut	15	Filter

Specification of coil

Valve type	Coil type	Power type	Frequency (Hz)	Voltage range	Electrical entry	Power Consumption (VA/W)	Insulation	Temp. rise(°C)
2KSA□030	CDA110 CLA110	AC	50	±15%	Terminal (CDA)	15.0VA	Class F	50
			60			11.0VA		40
		DC	-	±10%		6.5W		30
2KSA□050	CDA160 CLA160	AC	50	±15%	Grommet (CLA)	35.0VA	Class F	65
			60			30.0VA		60
		DC	-	±10%		12.0W		40

Valve's specification

Acting		Direct acting				
Initial state		Normally opened				
Adaptable fluid		Air, Water, Oil				
Viscosity limit		Under 20CST				
Ambient and fluid temperature (°C)		Water	Air	Oil	Ambient	
		Max. 80	90	80	70	
		Min. 1	-20 [Note1]	-10 [Note2]	-20	

[Note1] Dew point: -20(°C) or less ; [Note2] 50CST or less.

Ordering code

Ordering code of valves

2KSA H 030 08 A □ □



① Model	② Pressure condition	③ Size series	④ Port size	⑤ Voltage	⑥ Electrical entry	⑦ Thread type
2KSA: 2/2 way direct-acting and normally opened	X: Extra high pressure H: High pressure Blank: Standard L: Large volume	030: 030 Series 050: 050 Series	06: 1/8" 08: 1/4" 10: 3/8" 15: 1/2"	A: AC220V B: DC24V C: AC110V E: AC24V F: DC12V	Blank: Terminal I: Grommet[Note]	Blank: PT G: G T: NPT

[Note] The wire length is 0.5m.

Ordering code of accessories

Ordering code of accessories is the same as 2WA series valve's, Please refer to P164 for details of ordering code.



Fluid control valve(2/2 way)

2KSA Series (Direct-acting and normally opened)

Flow chart

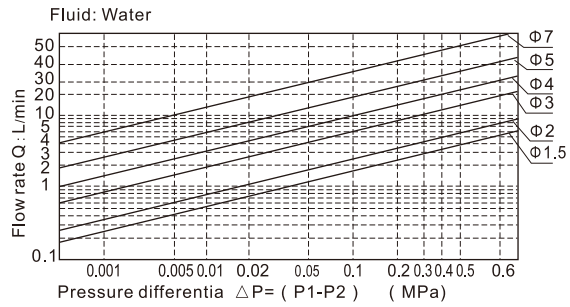
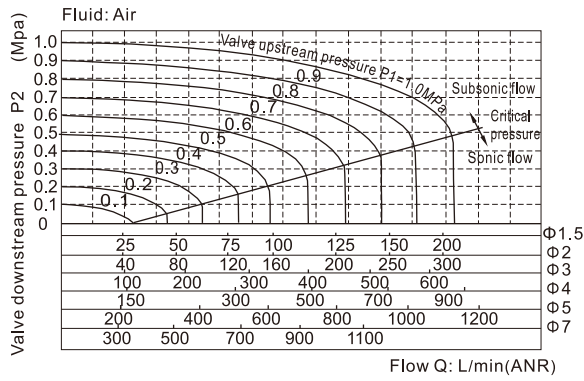

Dimensions

2KSA□030 (Terminal)

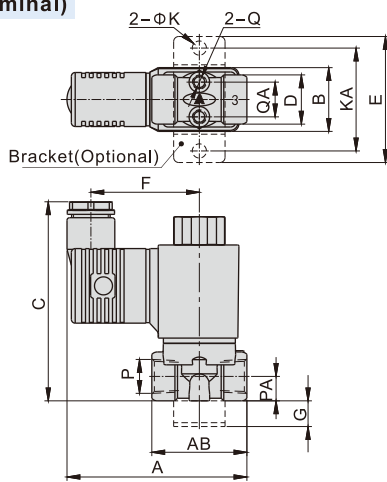

2KSA□030 (Grommet)

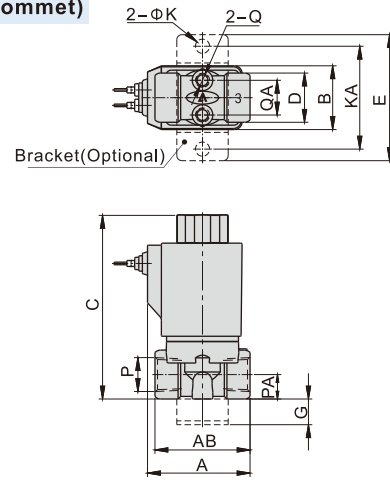

2KSA□050 (Terminal)

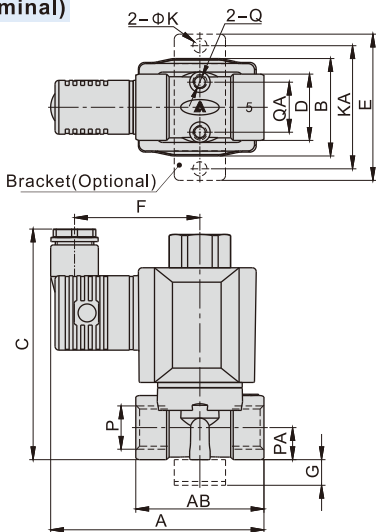

2KSA□050 (Grommet)

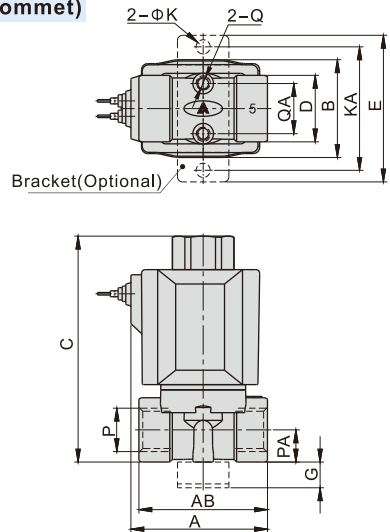

Model\Item	A	AB	B	C	D	E	F	G	K	KA	P	PA	Q	QA
2KSA□030-06	70	37	25	77.5	19	49	42	10	5.5	40	1/8"	9.5	M5	13.5
2KSA□030-08	70	37	25	77.5	19	49	42	10	5.5	40	1/4"	9.5	M5	13.5
2KSA□050-10	83	50	38	90	26	57	49	10	5.5	48	3/8"	12.5	M5	19.5
2KSA□050-15	83	50	38	90	26	57	49	10	5.5	48	1/2"	12.5	M5	19.5

Model\Item	A	AB	B	C	D	E	G	K	KA	P	PA	Q	QA
2KSA□030-06	40	37	25	74	19	49	10	5.5	40	1/8"	9.5	M5	13.5
2KSA□030-08	40	37	25	74	19	49	10	5.5	40	1/4"	9.5	M5	13.5
2KSA□050-10	53	50	38	90	26	57	10	5.5	48	3/8"	12.5	M5	19.5
2KSA□050-15	53	50	38	90	26	57	10	5.5	48	1/2"	12.5	M5	19.5

